

S-3000 FOLDAWAY

Dual-Panel Counterweight
Balanced Vertical Opening



RENLITA
Custom Opening Solutions

www.RenlitaUSA.com



ABOUT RENLITA

Renlita is the industry leader in custom doors, windows, and operable walls that transform architectural designs and define interior and exterior spaces. Customize one of our time-tested models or design your own one-of-a-kind, "never been done before" masterpiece. Our Design Consultants guide you through the creation of specially designed steel or aluminum vertical openings that blend in or stand out. **Come see why we're the clear-cut, safe, and trendsetting leader in vertical opening and custom metal architectural pieces.**



CONCEPT TO COMPLETION

Renlita provides a turnkey solution, including specified finish, glass or cladding, and installation. Every project is unique and built to meet your design needs. Our concept to completion service provides customers with confidence that all aspects of the project are properly executed.

STEP
01

CONCEPT

Our Design Consultants listen to your ideas and walk you through the process of designing the window, wall, door, or special project you've been envisioning.

STEP
02

CREATE

Renlita's engineers are the best in the business. We specifically design all parts of the system to match your design intent and provide drawings and details for your unique project.

STEP
03

CRAFT

Every single inch of your project is as important to us as it is to you. Each custom project is carefully handcrafted by a team of specialized artisans with pride in the USA.

STEP
04

COMPLETE

The most exciting part is bringing your project across the finish line! Renlita's factory trained technicians complete your custom project with expert installation and service.



S-3000 FOLDAWAY

Two steel framed panels and a whole lot of opportunity. With no need for ridiculous structural or excessive electrical costs even with a 90 foot max opening, this door still boasts the largest clear opening height of any 50/50 bifold on the market. The S-3000 model is designed for applications where minimal internal projection is required. We utilize counterweight balance technology to ensure smooth operation and durability, as well as customizations that no one else can do.

OPTIONS & FEATURES



Battery Back Up

The REDD® Battery Backup provides a secondary power source in the event of power loss.



Touch Screen Control

Our sleek touchscreen has plug-and-play technology and can be configured with a multi-digit code for security.



REDD® Motor

We designed a motor exclusively for our high-end products. These 110V motors are low-to-no maintenance, high performance, and only available from Renlita.



REDD Alert®

REDD Alert® is our integrated safety system that identifies anything impeding door travel to keep your system safe.



Safety Brake

Our patented safety brake is an additional level of assurance available only on Renlita products.

S-3000 DETAILS

- Max Width: 90 FT
- Max Height: 30 FT
- Finish: Powder Coat*
- Glass Options: 1/4" & 1" IGU
- High-Wind Load Areas: YES
- Miami Dade NOA: NO
- Cladding Options: Up to 4" & 15 lbs per SQF
- Operation: Motorized or Manual
- Flush Mount Available: NO
- Remote Weight Options: NO
- Compatible With Screens: NO
- NFRC Ratings: YES

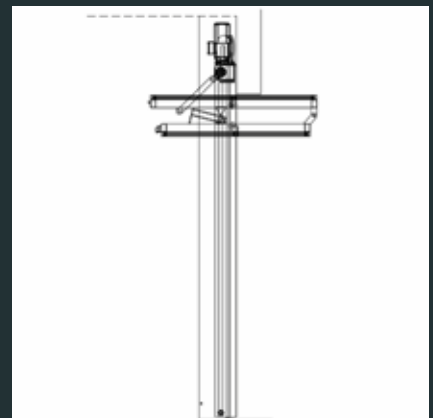

* Size Restrictions



VISIT OUR WEBSITE FOR MORE RESOURCES



Manuals



Drawings



AIA/CES Classes



Brochures



Galleries



Color Chart

www.RenlitaUSA.com



RENLITA
Custom Opening Solutions



(903) 568-3956



sales@renlitadoors.com



2430 Albert Broadfoot St.
Bonham, Texas 75418